



# FOREVER I REDWOOD

*From the Forest, For the Forest since 1995*

---

619-639-7503 or 619-677-1965 -Direct Lines for the Engineering Department

7am – 5pm Pacific Time, Monday - Friday

## ASSEMBLY INSTRUCTIONS FOR THE **THE PALOMAR ROUND PAVILION** **(CUSTOM)**

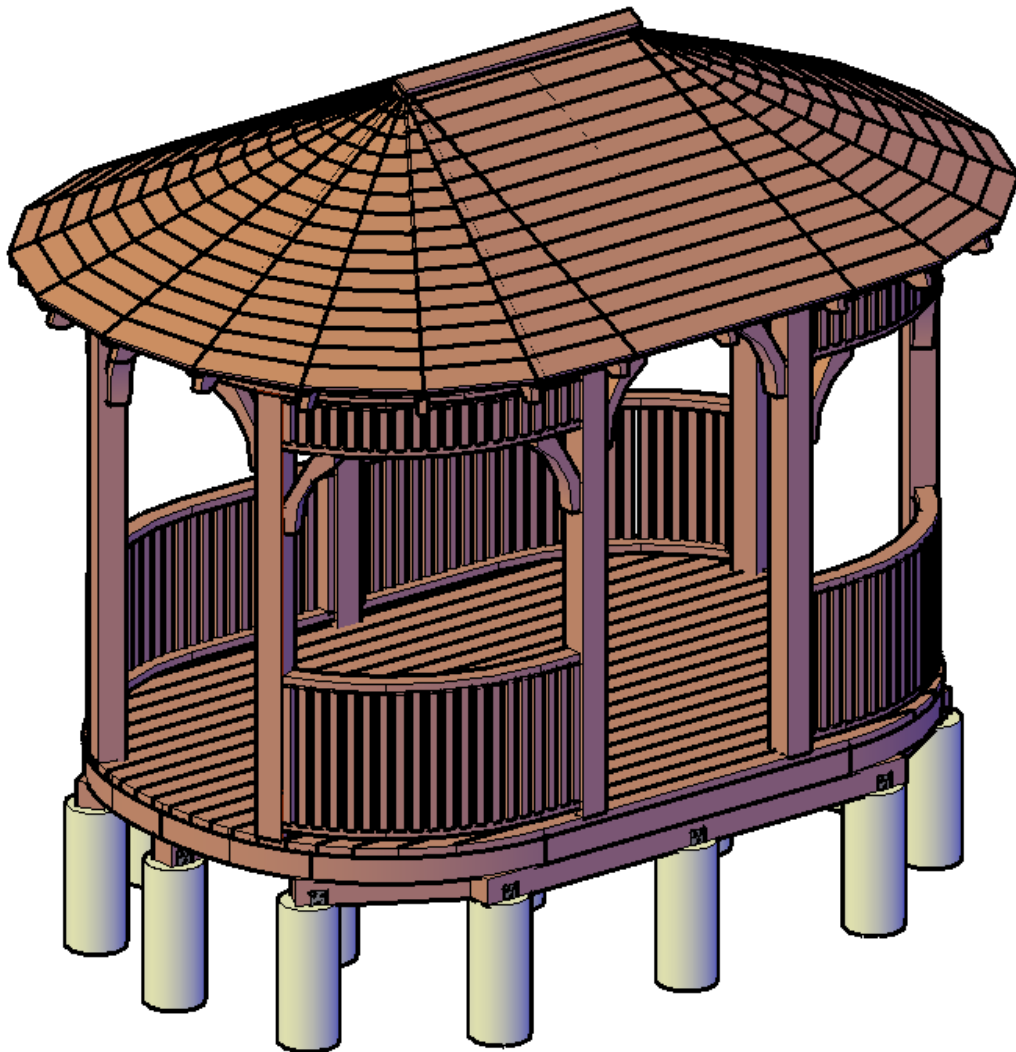

**NOTE:** To assemble your product, you need a Hammer, a Ratch, a Drill, and an impact drill. For bigger structures, a forklift may be needed too.

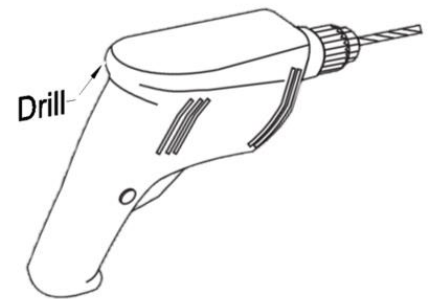
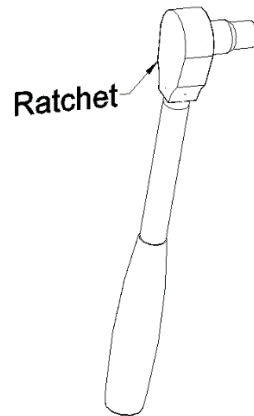
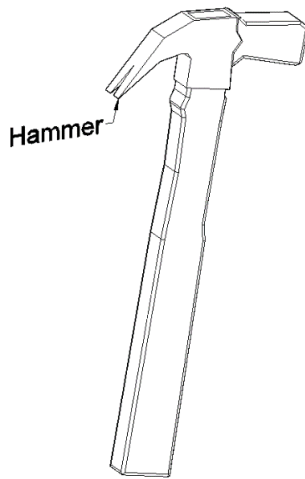

**Required Tools (Are not included in your hardware packing).**

**PROCESS TO INSTALL THE HARDWARE PROVIDED.**

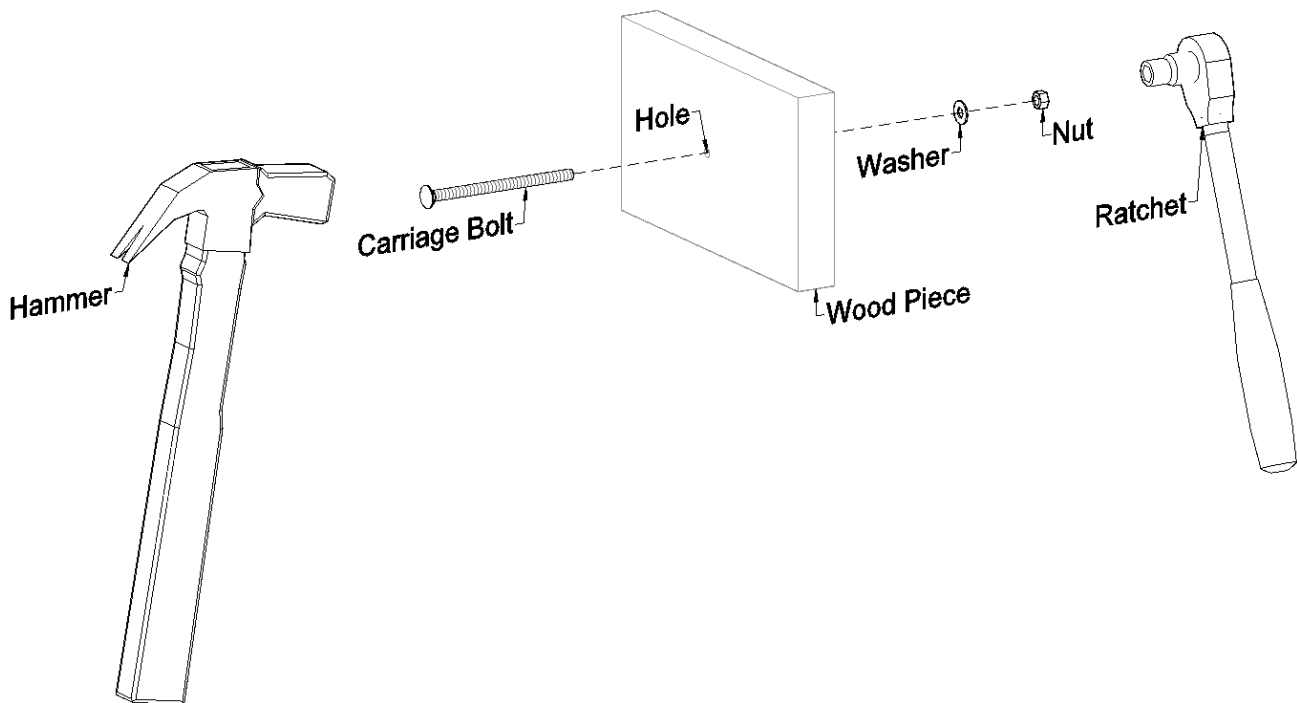

**To install the bolts.**

Insert the carriage bolts into the holes and lightly tap with a hammer until the square neck fit in the wood piece and the bolt head must flush with the wood piece. Finally, place the washer and the nut and carefully tighten it using a ratchet with the necessary socket or a wrench.

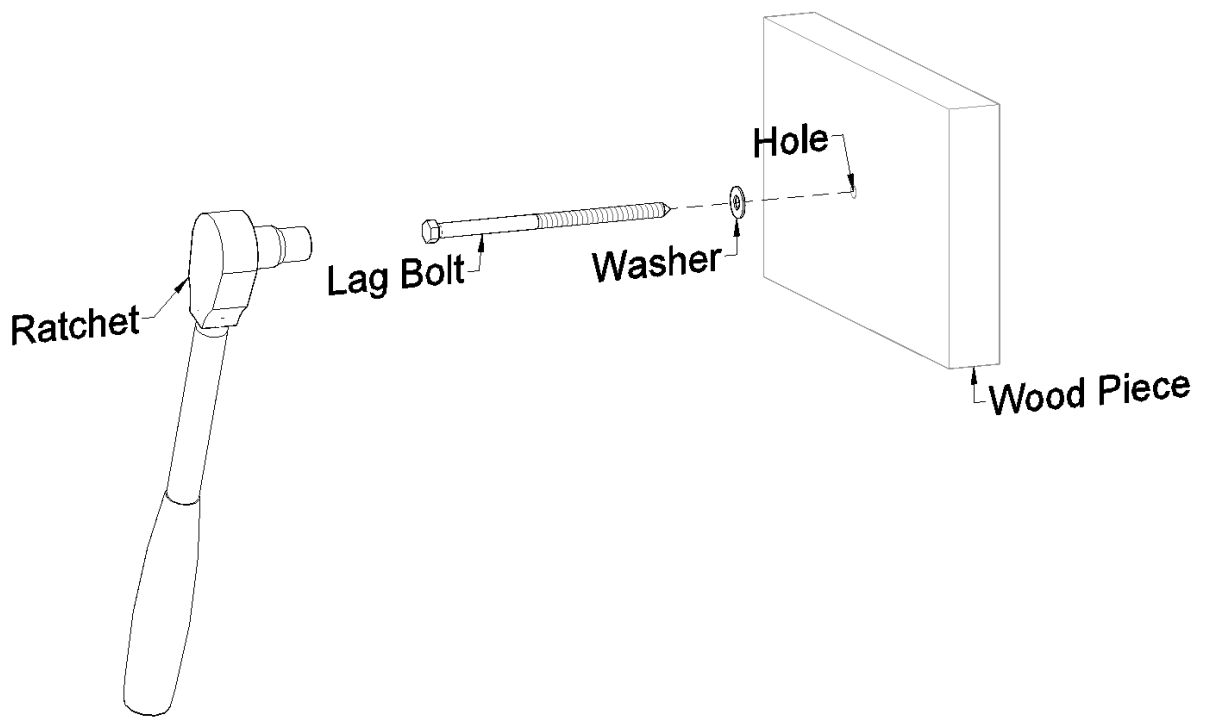

**To install the lag bolts.**

Place the washers in their lag bolts. After that, insert the lag bolts into the holes and carefully tighten it using a **ratchet** with the necessary **socket**.

**Use the washers only for the Wood Pieces.**

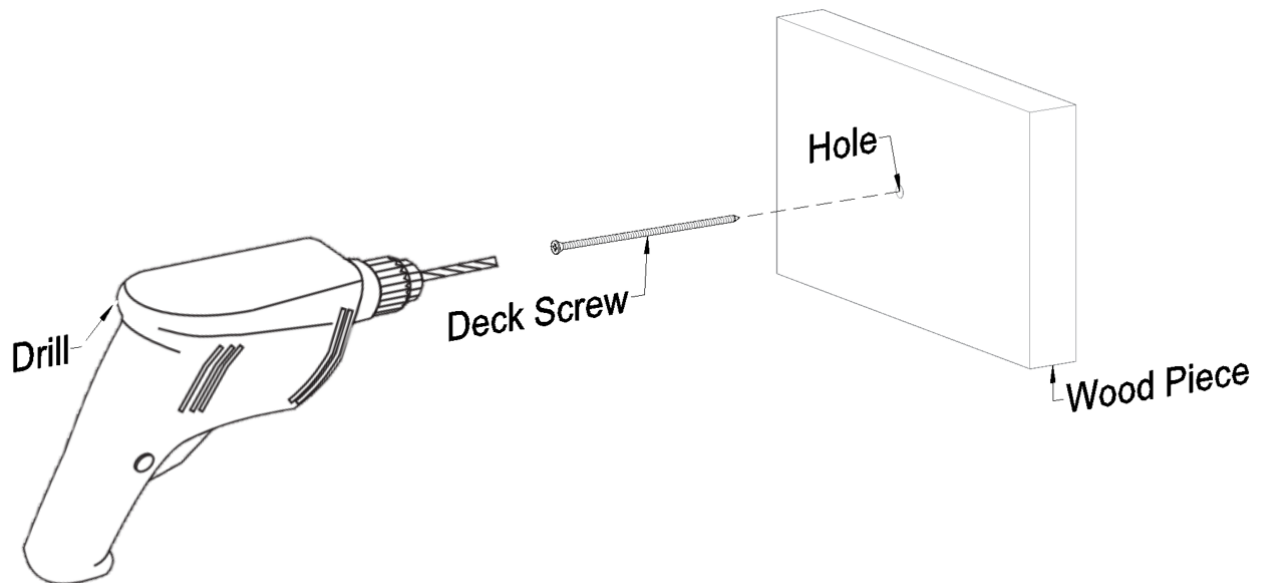

**To install the deck screws.**

Insert the deck screws into the holes and carefully tighten it using a drill.

**Step 1:** Install the L-Brackets to the ground with 1/2" x 4" anchor bolts.

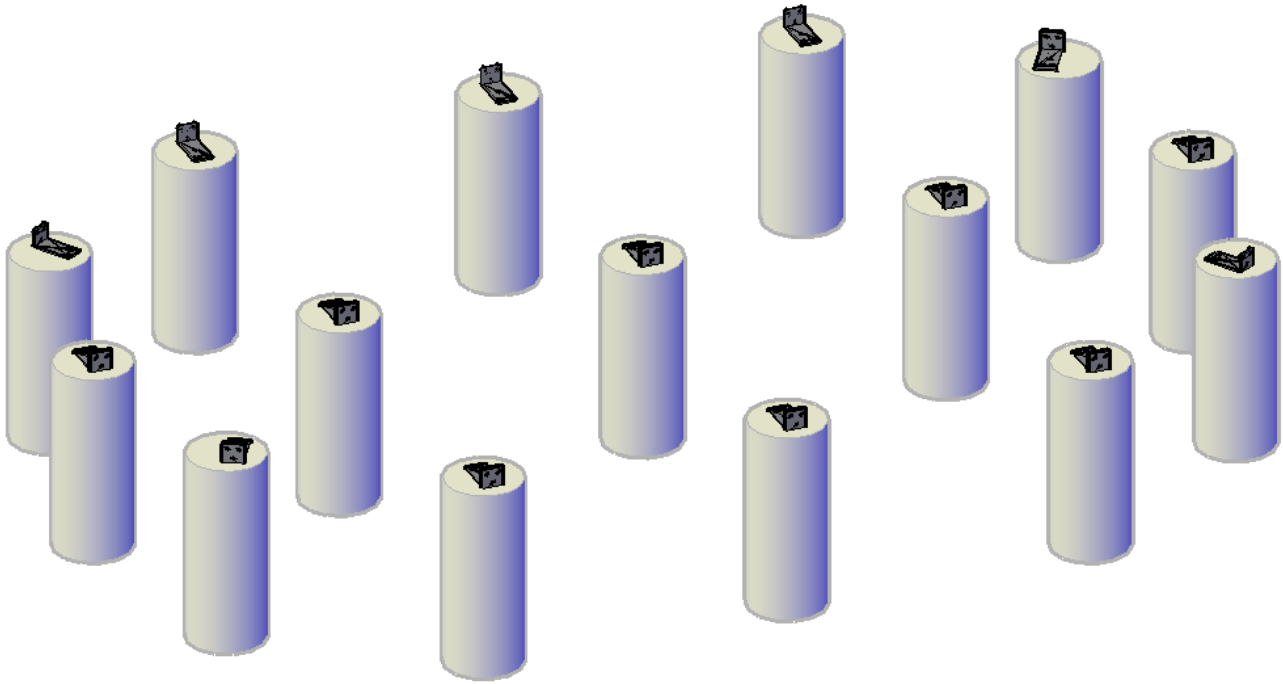

**Step 2:** Attach the floor supports with 3/8" x 6" lag bolts (→) and 3/8" x 8" lag bolts (→).

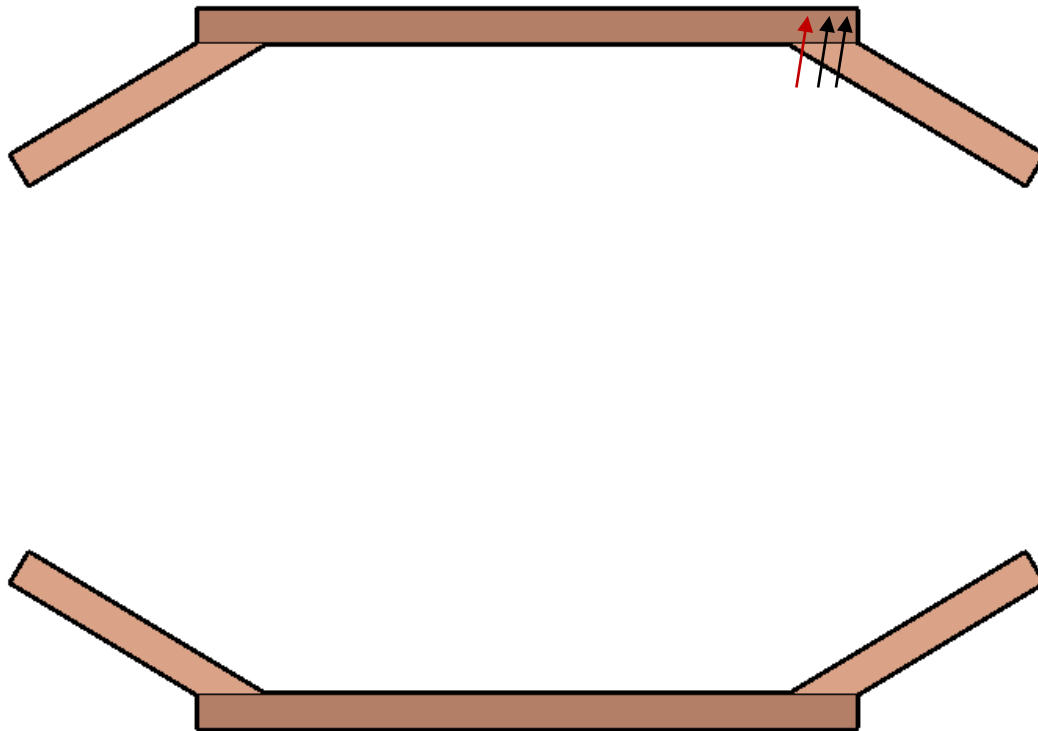

**Step 3:** Attach the floor supports to the L-Brackets with 5/16" x 3" Lag Bolts.

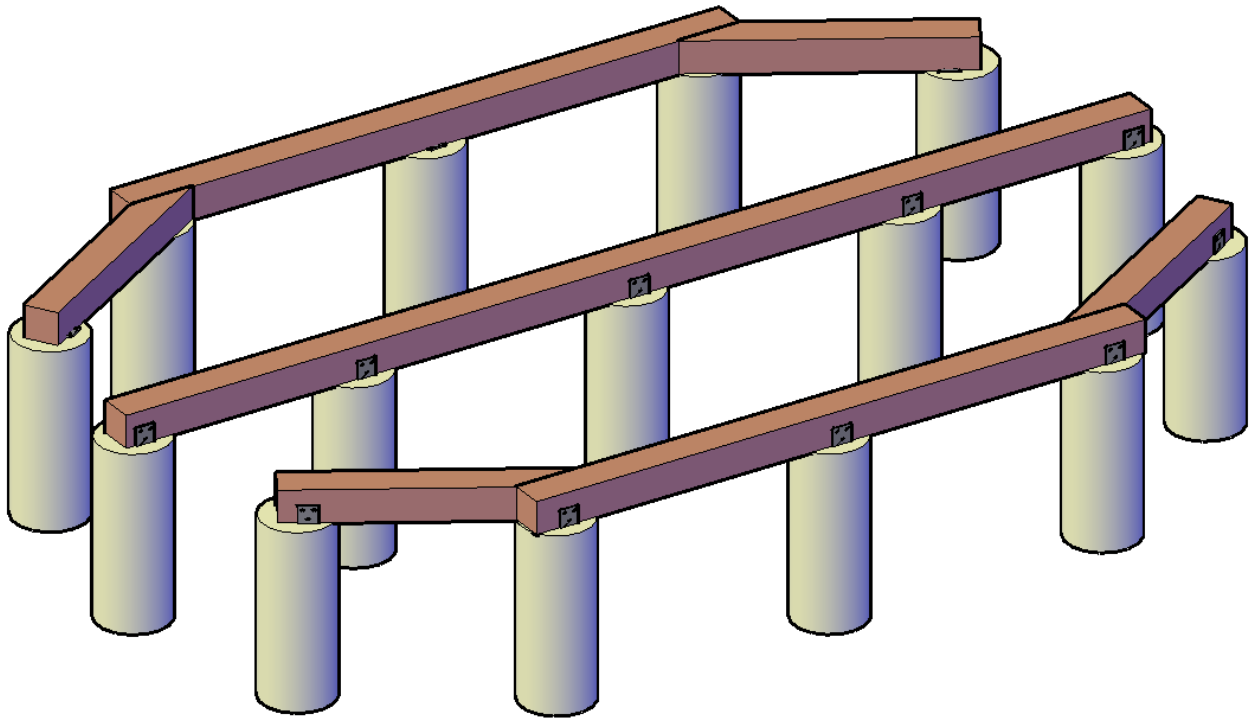

**Step 4:** Assemble the frame floor with 3" deck screws.

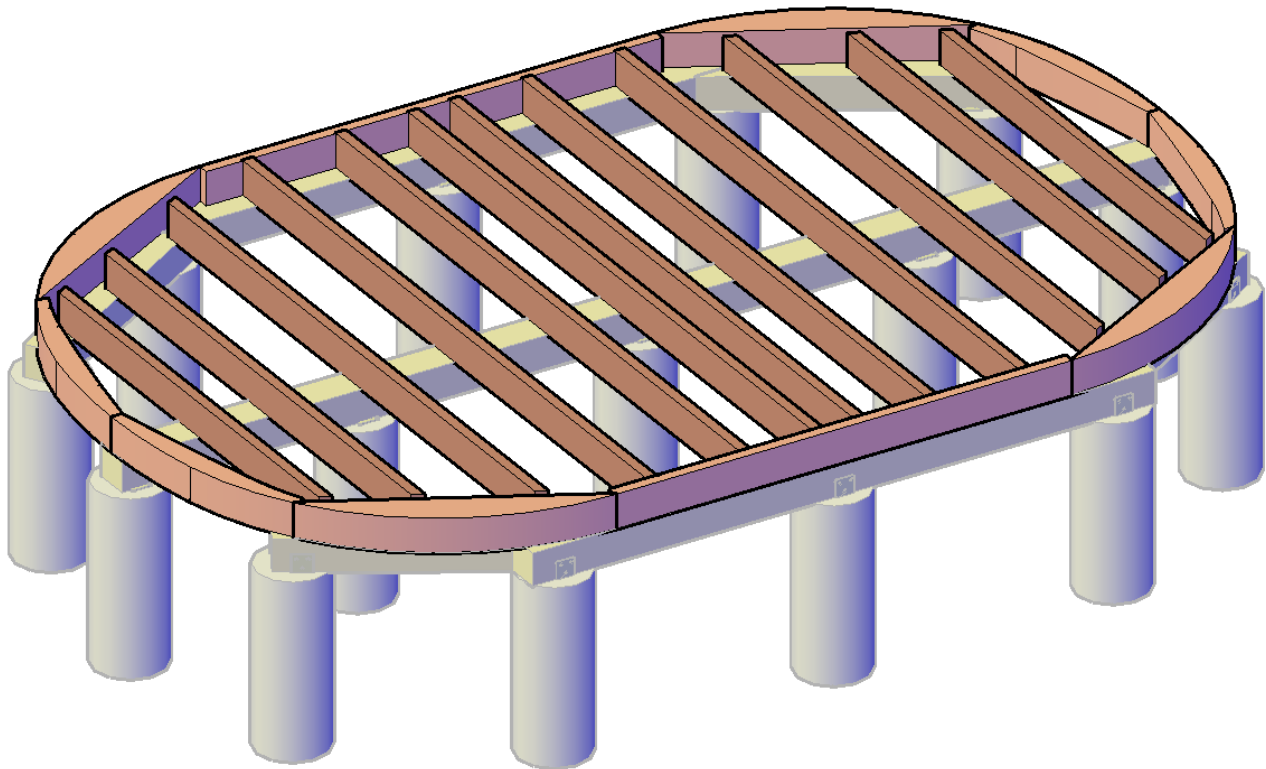

**Step 5:** Attach the floor boards with 2 1/2" deck screws.

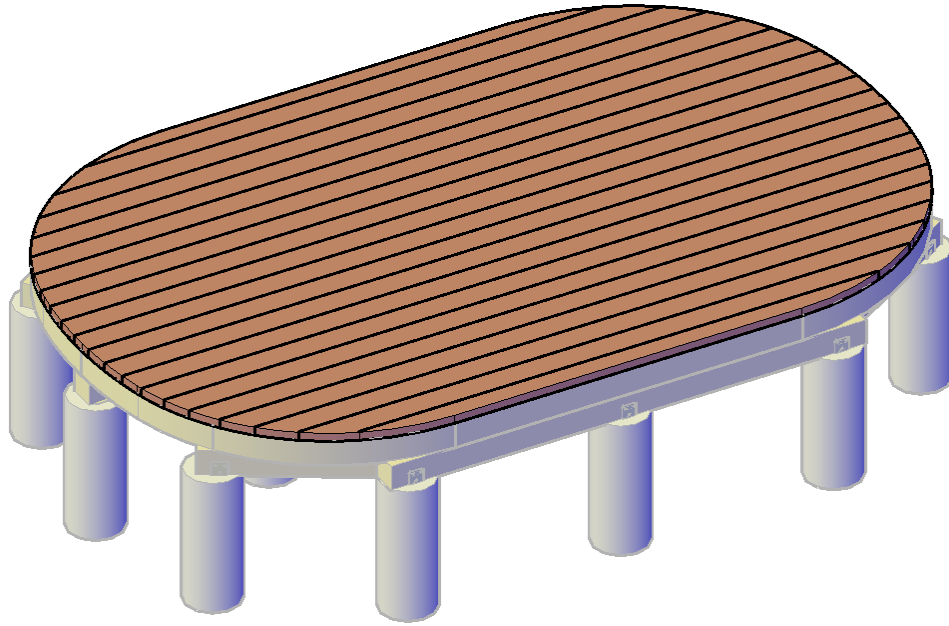

**Step 6:** Use 3/8" x 4" lag bolts to attach the posts to the floor.

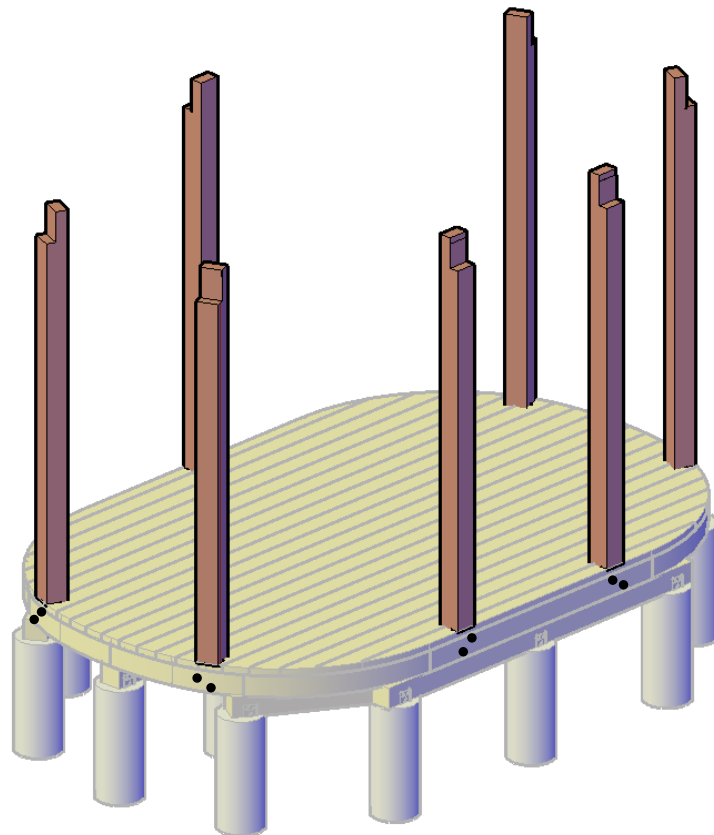

**Step 7:** Attach the supports to the posts with 3/8" x 5 1/2" bolts (●). The supports will be attached together with 3/8" x 8" bolts (→).

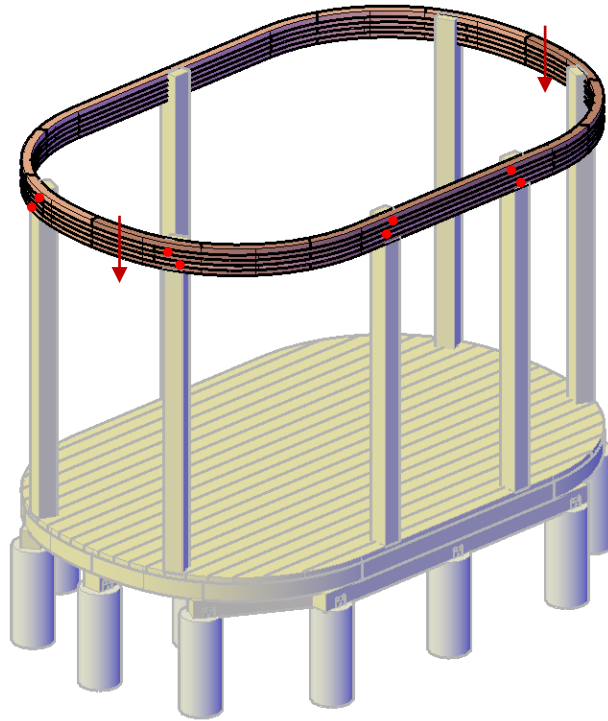

**Step 8:** Use 5/16" x 3" lag bolts to attach the railings to the posts, the floor and to the supports.

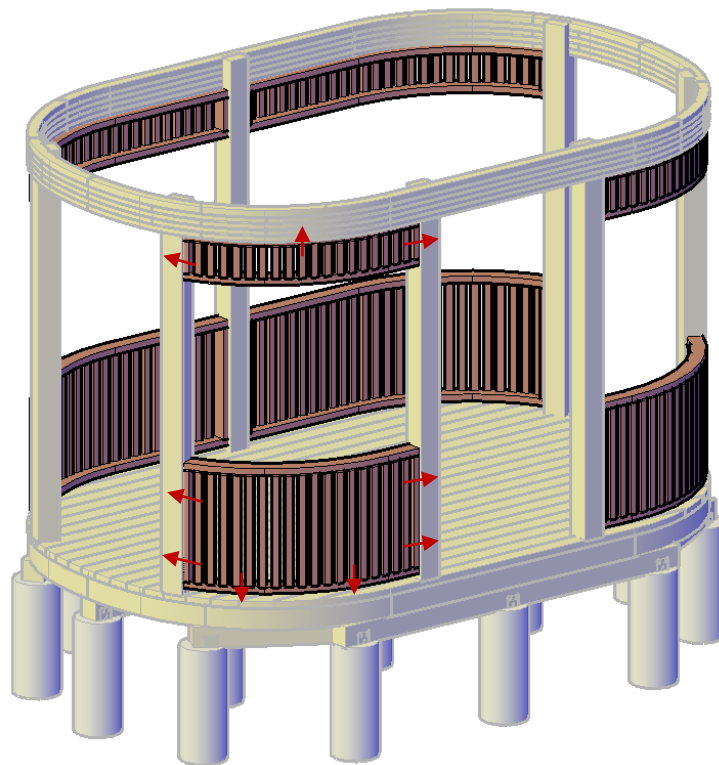

**Step 9:** Attach the braces to the posts with 3/8" x 8" bolts (→) and 3/8" x 10" bolts (→).

**Step 9.1:** Use 3/8" x 6" bolts (→) to attach the braces to the supports.

**Step 9.2:** Use 3/8" x 7" bolts (→) to attach the braces to the railings.

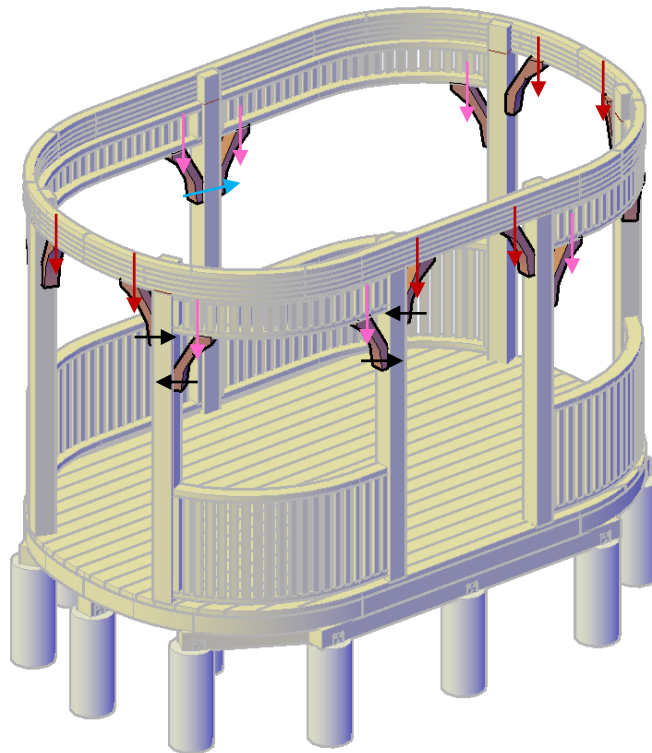

**Step 10:** Attach rafters to the supports with 3/8" x 10" (→) and 3" deck screws. After that, attach to the ridge beam with 3/8" x 6" lag bolts (→).

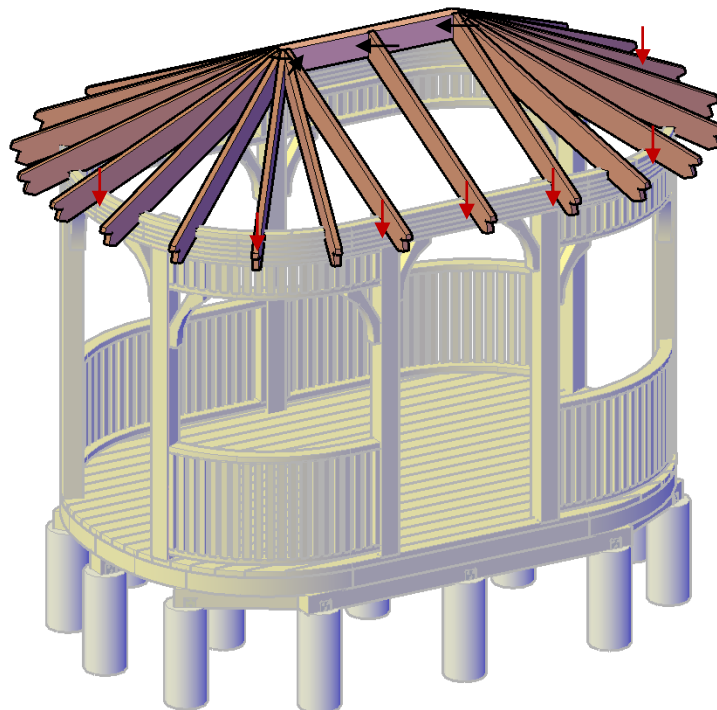



**Step 11:** Use 1 5/8" deck screws to attach the roof boards T&G to the rafters.

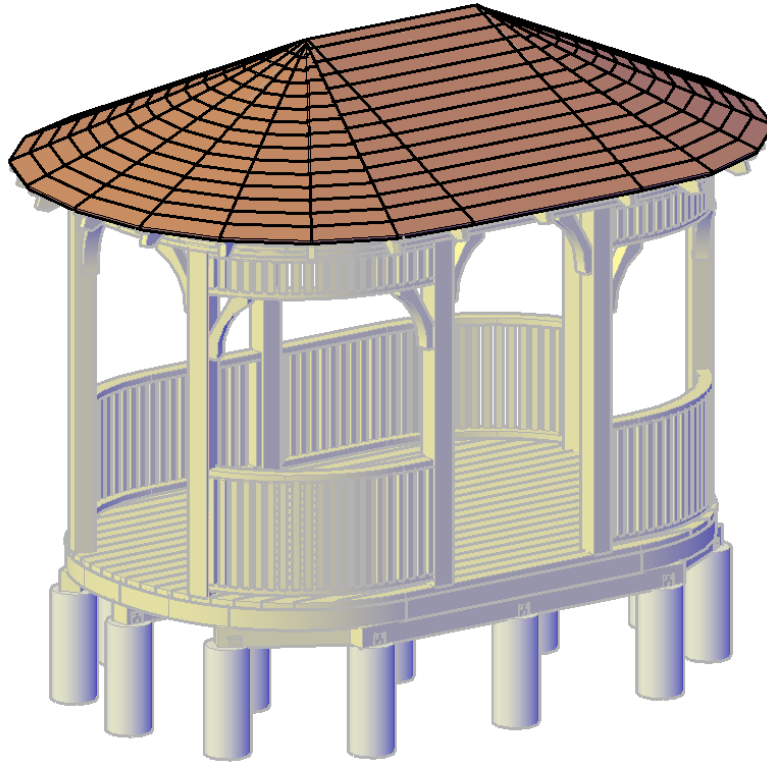

**Step 12:** Use 1 5/8" deck screws to attach the overlapping roof boards the rof boards T&G.

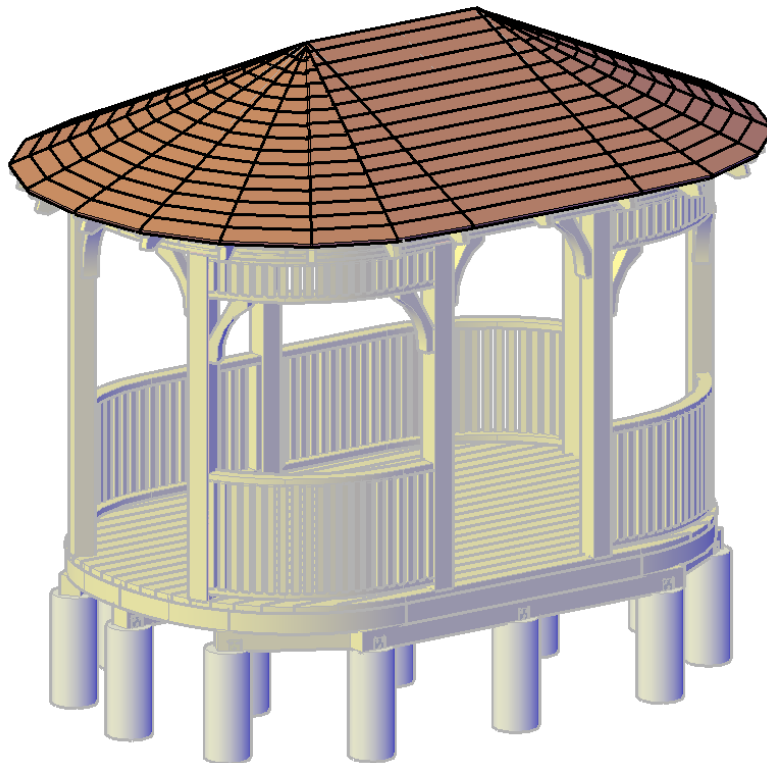

**Step 13:** Use 4'' deck screws to attach covers to the roof boards.

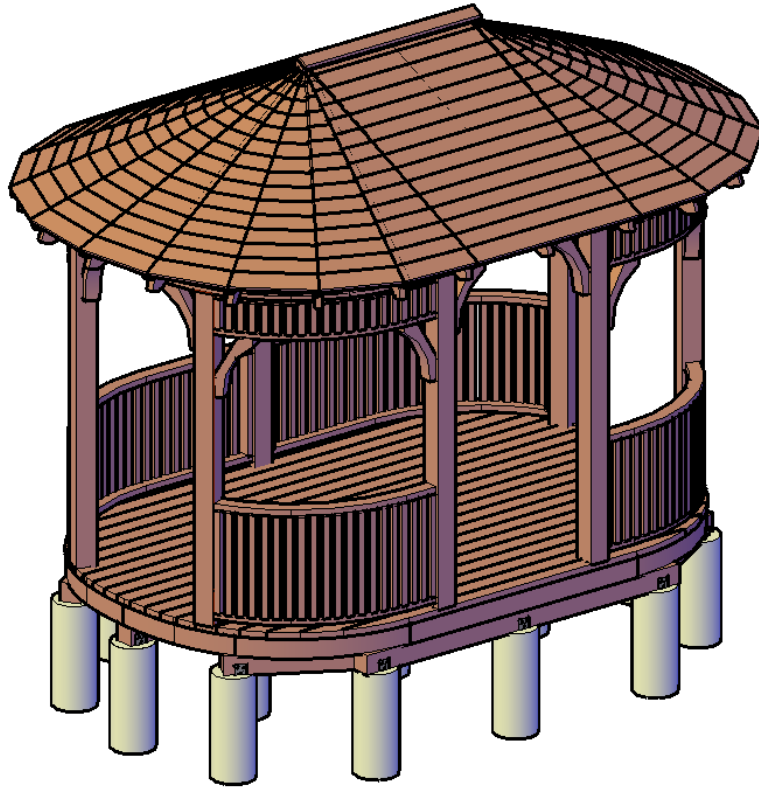

**Step 14:** Finally, use 5/16'' x 5'' bolts to attach the ceiling fan base.

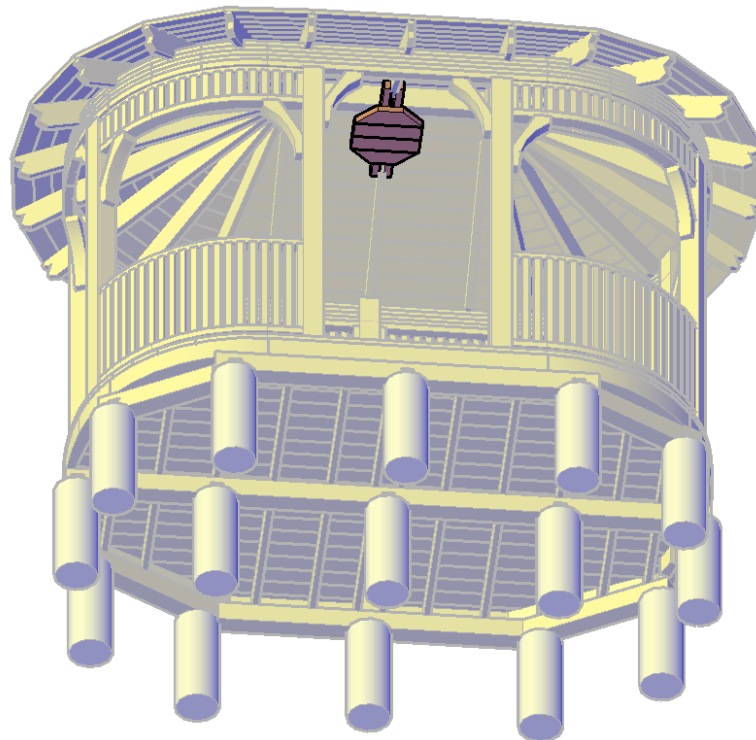



*This completes the Pavilion Assembly. Hope you enjoy your set for many decades. If you ever have a problem or a question, don't hesitate to call us (619-639-7503 or 619-677-1965) or email us. We are here to support you.*

