



FOREVER I REDWOOD

From the Forest, For the Forest since 1995

619-639-7503 or 619-677-1965 -Direct Lines for the Engineering
Department

7am – 5pm Pacific Time, Monday - Friday

ASSEMBLY INSTRUCTIONS FOR THE **FRED & WILMA'S FAVORITE COFFEE TABLE**

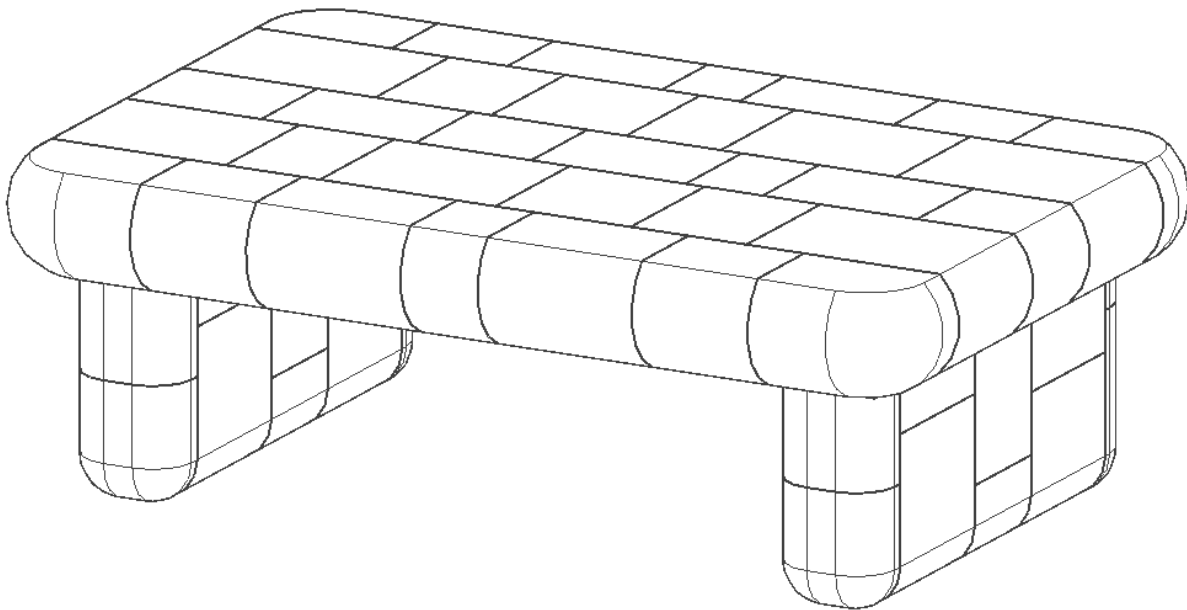

NOTE: To assemble your product, you need a Hammer, a Ratch, a Drill, and an impact drill. For bigger structures, a forklift may be needed too.

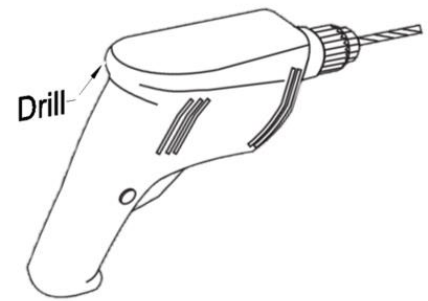
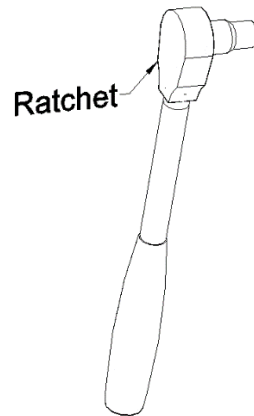
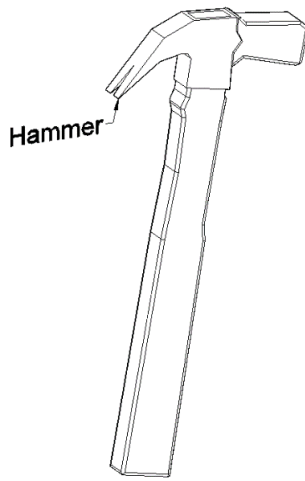

Required Tools (Are not included in your hardware packing).

PROCESS TO INSTALL THE HARDWARE PROVIDED.

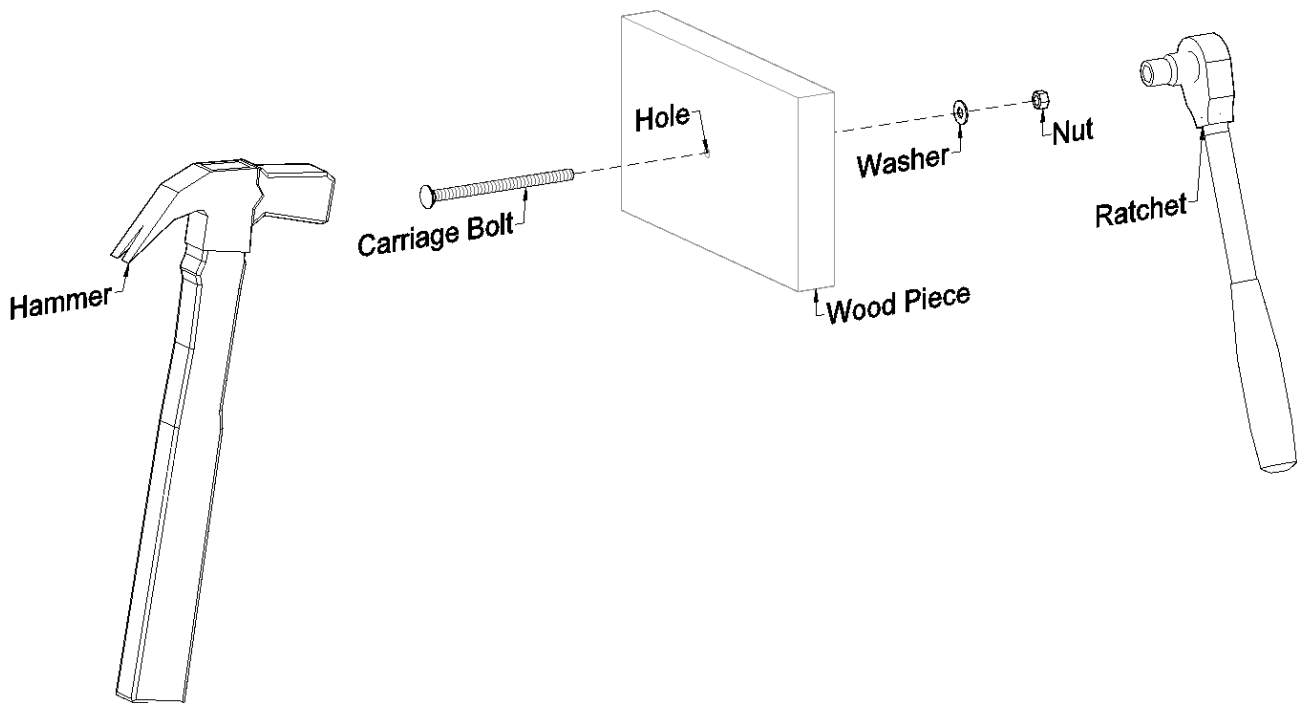

To install the bolts.

Insert the carriage bolts into the holes and lightly tap with a hammer until the square neck fit in the wood piece and the bolt head must flush with the wood piece. Finally, place the washer and the nut and carefully tighten it using a ratchet with the necessary socket or a wrench.

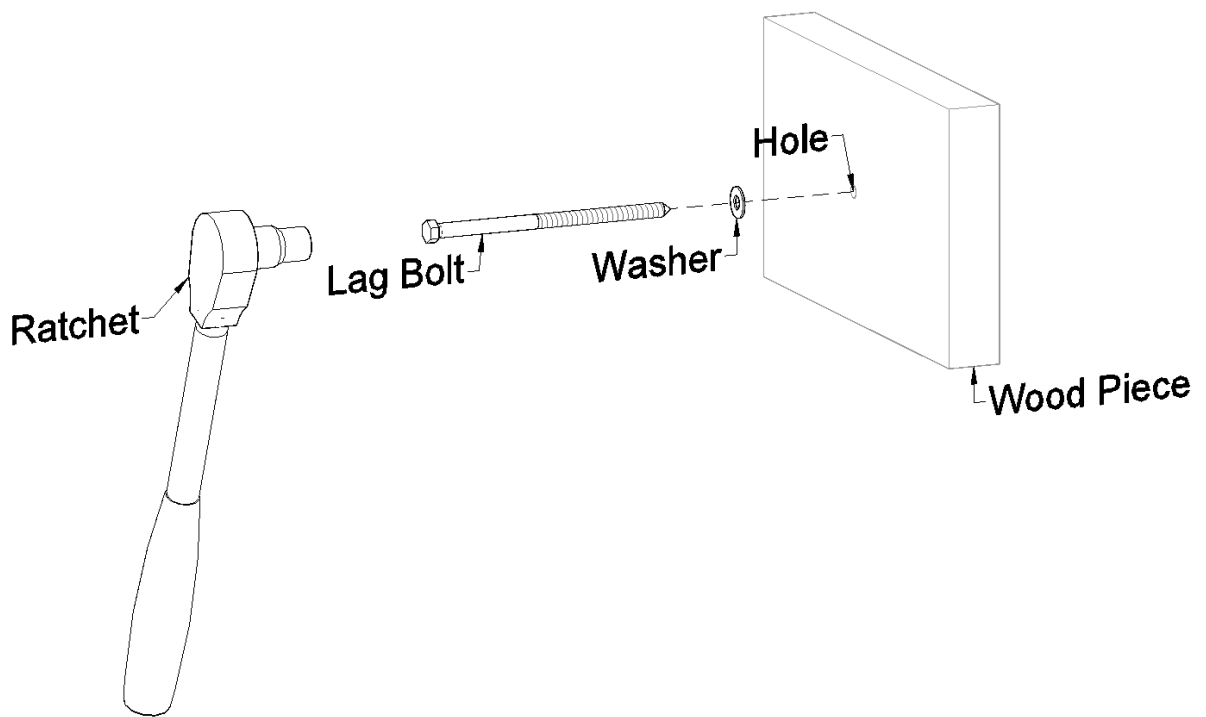

To install the lag bolts.

Place the washers in their lag bolts. After that, insert the lag bolts into the holes and carefully tighten it using a **ratchet** with the necessary **socket**.

Use the washers only for the Wood Pieces.

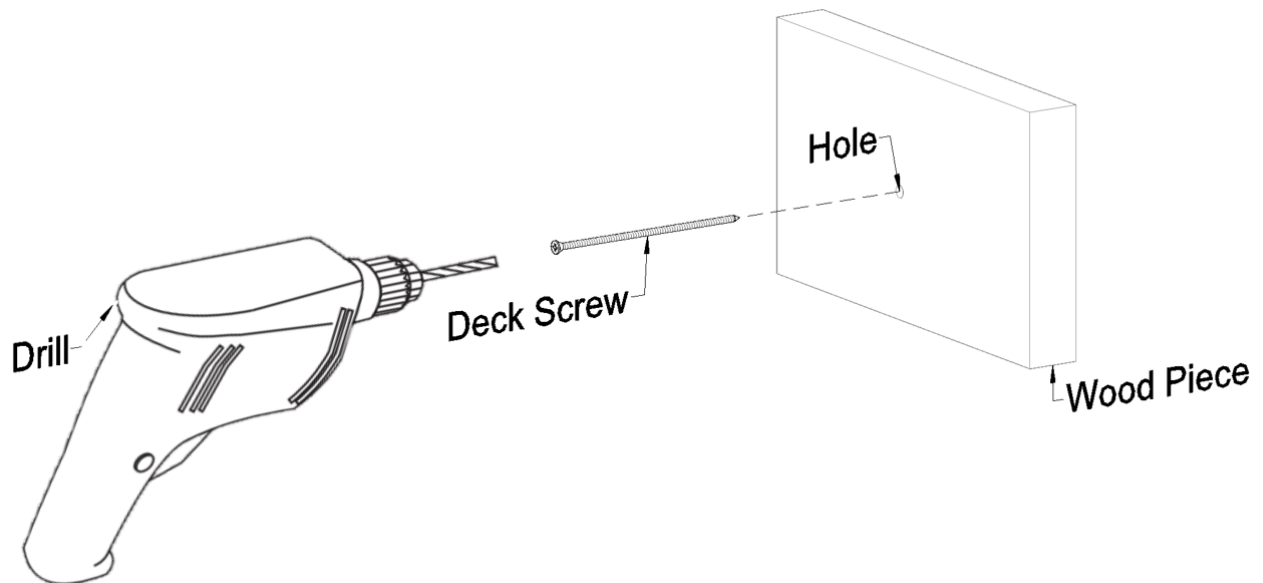

To install the deck screws.

Insert the deck screws into the holes and carefully tighten it using a drill.

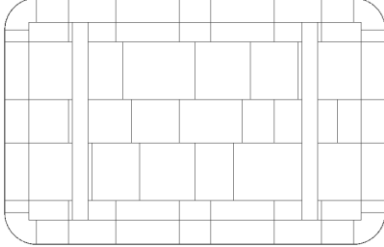
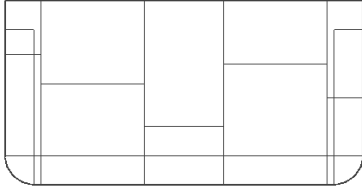

CONTENT OF BOXES			
Qty.	Description	Drawing	No.
1	Tabletop		1
2	Legs		2

Note: Part numbers in the Content of Boxes Table are for reference only. These do not match to the numbers marked on the parts sent.

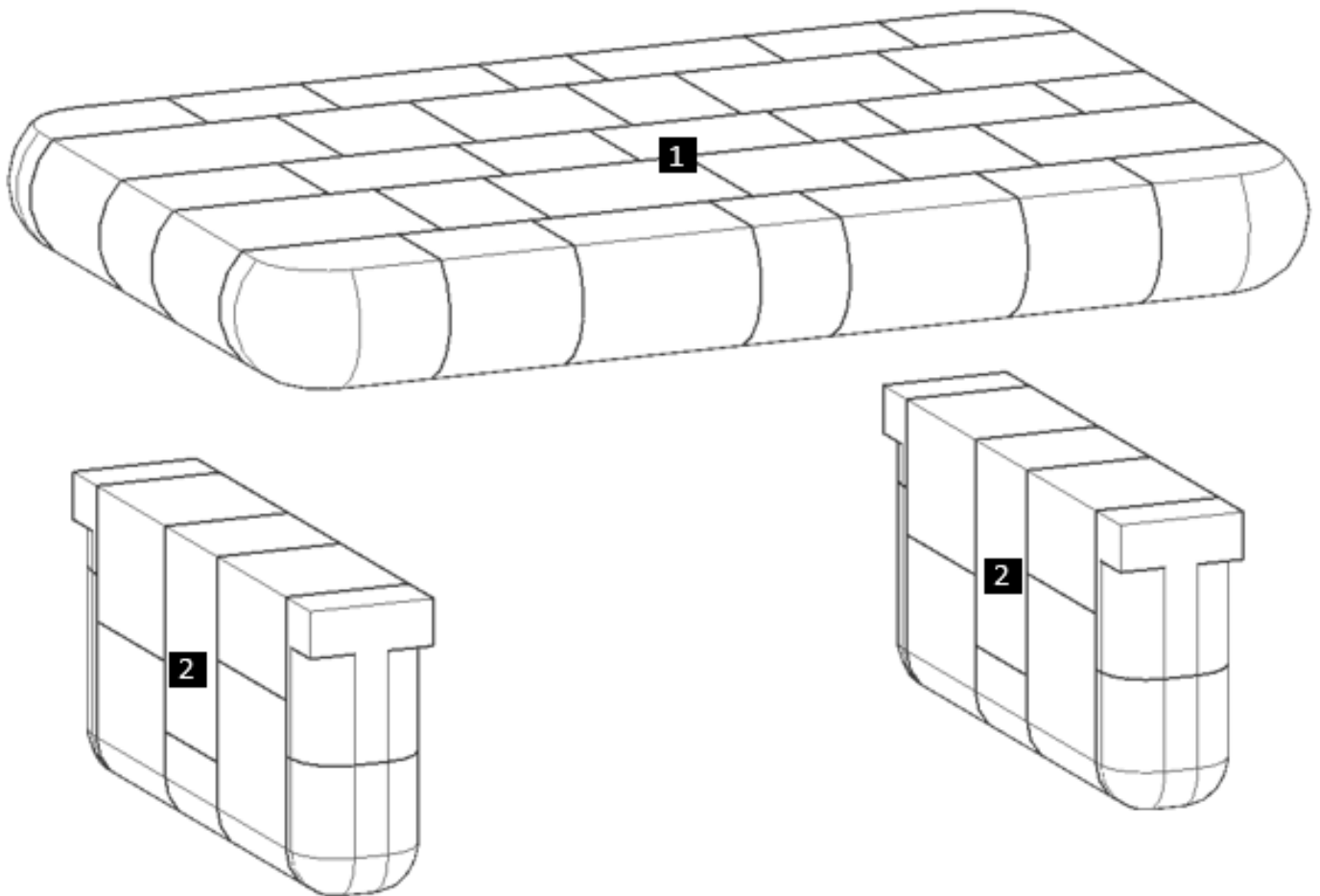
DESCRIPTION	No.
Tabletop	1
Legs	2



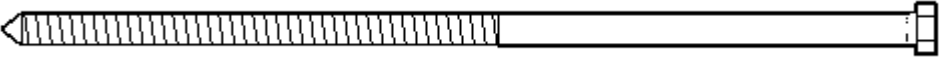

Note: Part numbers in the Drawing are for reference only. These do not match to the numbers marked on the parts sent.

HARDWARE LIST			
Qty.	Description	Drawing	No.
6	3/8" x 12" lag bolts		LB1
6	3/8" washers		WS

HARDWARE ASSEMBLY GUIDE

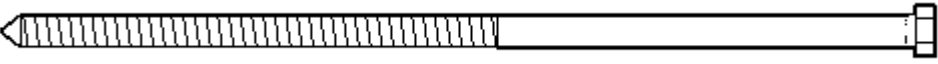
Step 2: Place the Table upside down. After that, use 3/8" x 12" lag bolts (**LB1**) to attach the legs (**2**) to the Tabletop (**1**). Each part has a series of numbers that indicate where to attach the part with the corresponding number.

REQUIRED HARDWARE			
Qty.	Description	Drawing	No.
6	3/8" x 12" lag bolts		LB1
6	3/8" washers		WS

Step 2: Finally, turn the table over its feet.

Step 1:

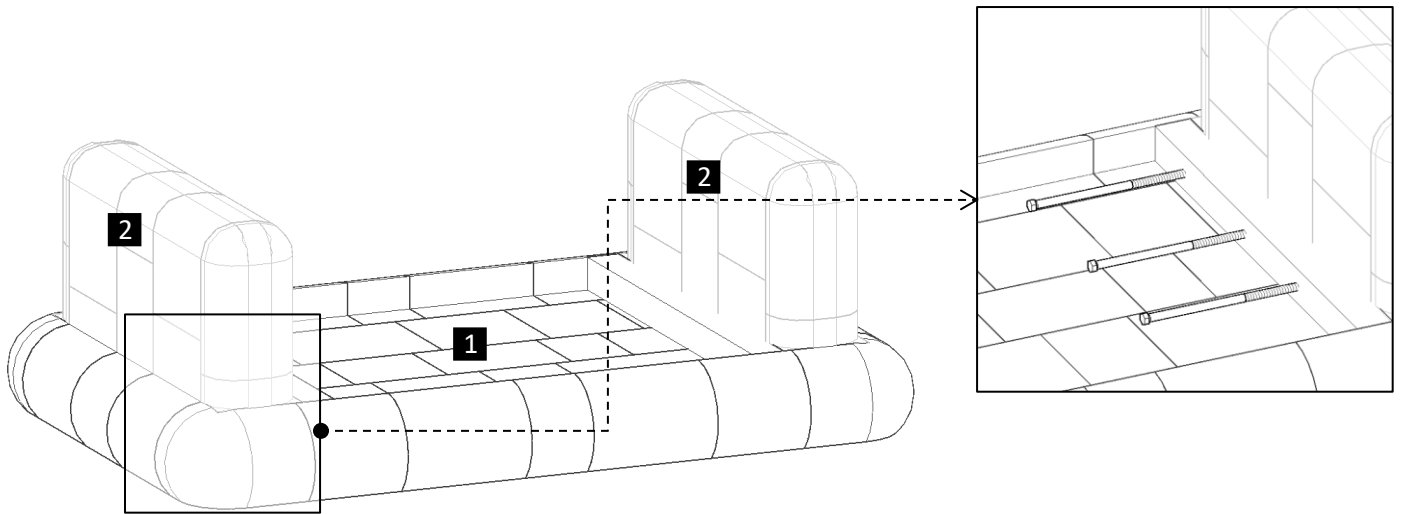

Step 2:

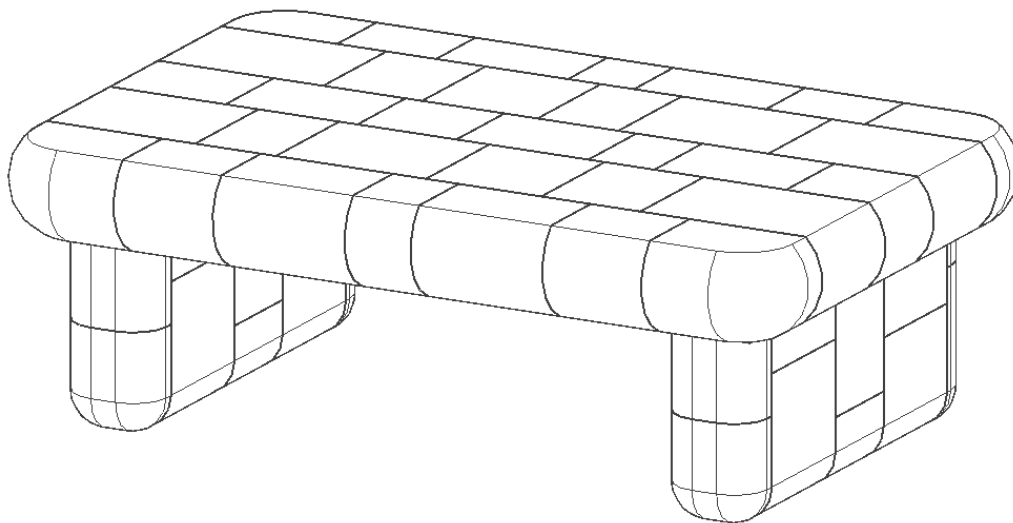

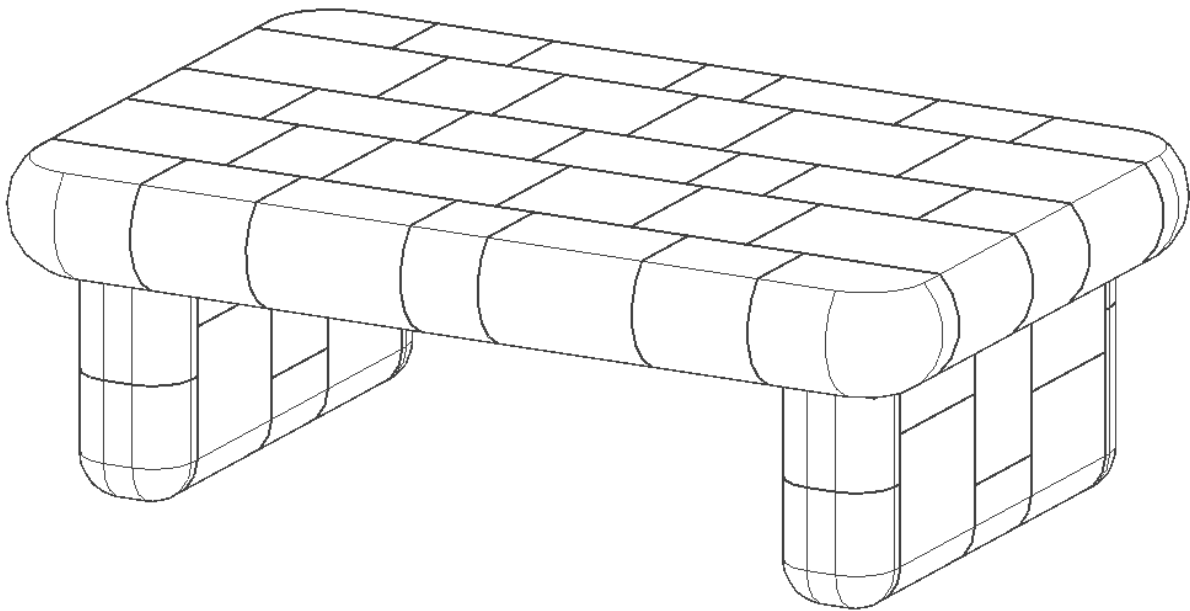

This completes the coffee table assembly. Hope you enjoy your set for many decades. If you ever have a problem or a question, don't hesitate to call us (619-639-7503 or 619-677-1965) or email us. We are here to support you.

